

ARTICULO: 2540

Válvula de esfera de tres vías Tipo "L", extremos bridados Flanged Ends Three Way ball valve, Type "L"

Características

1. Válvula esfera tres vías paso total.
2. Configuración de Esfera en "L".
3. Extremos Bridados según EN 1092.
PN40 desde DN 25 hasta DN 50.
PN16 desde DN 65 hasta DN 100.
4. Construcción en acero inoxidable 1.4408 (CF8M).
5. Norma de diseño DIN 3357 / EN 12516-1.
6. Cuatro asientos PTFE + 15 % Fibra de Vidrio (otros materiales consultar).
7. Tórica de FKM (Viton) en el eje.
8. Dispositivo Anti-estático.
9. Sistema de bloqueo.
10. Montaje actuador directo s/ ISO 5211.
11. Eje inexpulsable.
12. Presión de trabajo máxima 16/40 bar, según medida.
13. Temperatura de trabajo -25 °C + 180 °C.

Features

1. Stainless steel full port ball valve.
2. "L" Ball configuration.
3. Flanges ends according to EN 1092.
PN40 from DN 25 to DN 50.
PN16 from DN 65 to DN 100.
4. Made of stainless steel 1.4408 (CF8M).
5. Design according to DIN 3357 / EN 12516-1.
6. Four Ball seats PTFE + 15 % G.F.
(please ask for other materials).
7. FKM (Viton) o'ring in the stem.
8. Anti-static device.
9. Locking system.
10. Direct mounting actuator according to ISO 5211.
11. Blow-out proof stem.
12. Max. working pressure 16 / 40 bar, according to size.
13. Working Temperature -25 °C + 180 °C.

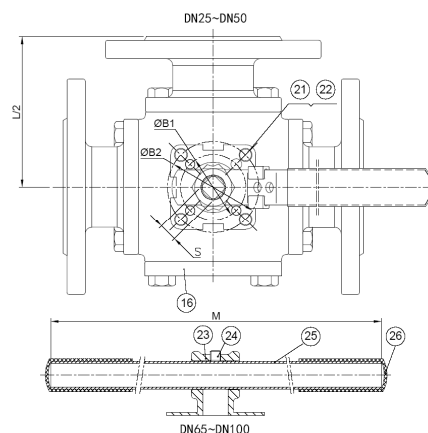
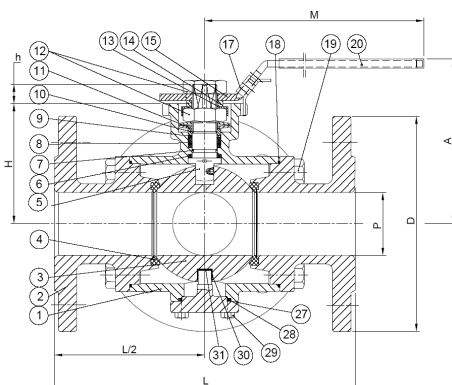
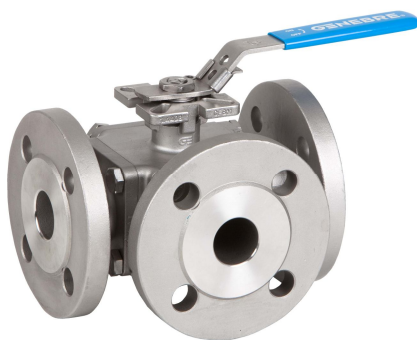

Nº	Denominación / Name	Material	Acabado Superficial / Surface Treatment	Cód. Recambio Spare Part Code
1	Cuerpo / Body	Acero Inox. / Stainless Steel 1.4408	Granallado / Shot blasting	-----
2	Tapa / Cap	Acero Inox. / Stainless Steel 1.4408	Granallado / Shot blasting	-----
3*	Bola / Ball	Acero Inox. / Stainless Steel 1.4408	-----	B2540
4*	Asiento / Ball Seat	PTFE + 15% F.V. / PTFE + 15% G.F.	-----	2928
5	Eje / Stem	Acero Inox. / Stainless Steel AISI 316	-----	-----
6*	Anillo Fricción / Thrust washer	PTFE	-----	2928
7*	Tórica / O' ring	FKM	-----	2928
8*	Empaquetadura / Stem packing	PTFE	-----	2928
9*	Casquillo / Bushing	Inox. + PTFE / S.S. + PTFE	-----	2928
10	Anillo Prensa / Gland	Acero Inox. / Stainless Steel AISI 316	-----	-----

Nº	Denominación / Name	Material	Acabado Superficial / Surface Treatment	Cód. Recambio Spare Part Code
11	Arandela Resorte / Spring Washer	Acero Inox. / Stainless Steel AISI 301	-----	-----
12	Tuerca vástago / Stem Nut	Acero Inox. / Stainless Steel AISI 304	-----	-----
13	Antigiros / Nut Locker	Acero Inox. / Stainless Steel AISI 304	-----	-----
14	Arandela / Washer	Acero Inox. / Stainless Steel AISI 304	-----	-----
15	Maneta / Handle (DN25-DN50)	Acero Inox. / Stainless Steel AISI 304	-----	-----
16	Tapa ciega / End Cap	Acero Inox. / Stainless Steel 1.4408	Granallado / Shot blasting	-----
17	Bloqueo maneta / Lock device (DN25-DN50)	Acero Inox. / Stainless Steel AISI 304	-----	-----
18*	Junta / Gasket	PTFE	-----	2928
19	Tornillo / Bolt	Acero Inox. / Stainless Steel AISI 304	-----	-----
20	Funda / Handle Sleeve	Vynil	-----	-----
21	Tornillo Tope / Stop Bolt	Acero Inox AISI 304 / SS 304	-----	-----
22	Tuerca / Nut	Acero Inox AISI 304 / SS 304	-----	-----
23	Adaptador Maneta / Handle Adapter (DN65-DN100)	Acero Inox AISI 304 / SS 304	Granallado / Shot blasting	-----
24	Tornillo / Bolt	Acero Inox AISI 304 / SS 304	-----	-----
25	Maneta / Handle	ASTM A 53	Cincado / Zn Plated	-----
26	Funda / Handle Sleeve	Vynil	-----	-----
27	Tapa Inferior / Bottom Cap	Acero Inox AISI 316 / SS 316	Granallado / Shot blasting	-----
28*	Junta / Gasket	PTFE	-----	2928
29	Tornillo / Bolt	Acero Inox AISI 304 / SS 304	-----	-----
30*	Casquillo / Bush	PTFE	-----	2928
31*	Disco / Disk	PTFE	-----	2928

* Piezas de recambio disponibles / Available spare parts

DIMENSIONES GENERALES / GENERAL DIMENSIONS

Ref.	Medida/ Size	PN	P	Dimensiones / Dimensions (mm)						ISO 5211 (ØB1/B2)	Peso / Weight (Kg)	
				L	ØD	H	A	M	S			h
2540 06	1"	40	25	180	115	68	99	175	11	11	F04/F05	8,600
2540 07	1 ¼"	40	32	190	140	72	103	175	11	11	F04/F07	11,800
2540 08	1 ½"	40	38	212	150	85	119	200	14	14	F05/F07	14,700
2540 09	2"	40	49	230	165	92	126	200	14	14	F05/F07	19,700
2540 10	2 ½"	16	63	290	185	107	172	400	17	17	F07/F10	33,300
2540 11	3"	16	75	310	200	119	187	400	17	18	F07/F10	47,100
2540 12	4"	16	99	350	220	150	214	400	22	22	F10	73,700

Dispositivo Antiestático / Anti-static Device

Este dispositivo nos garantiza la continuidad eléctrica entre esfera - eje - cuerpo, esto es de especial necesidad en fluidos inflamables / This device ensures the electrical continuity between Ball - Stem - Body, this is of special need in flammable fluids.

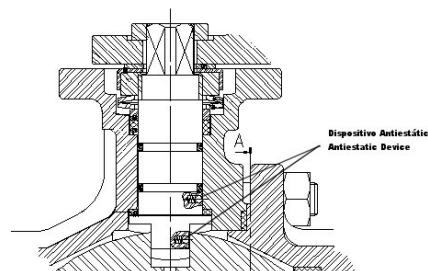

Configuraciones de flujo para válvula de tres vías “L – PORT” giro 90°/ *Flow Patterns for “L-PORT” 3 way valves 90° turn.*



VALORES DE Kv / Kv VALUES

K_v (m^3/h) = Es la cantidad de metros cúbicos por hora que pasará a través de la válvula generando una pérdida de carga de 1 bar.

K_v (m^3/h) = *Flow rate of water in cubic meter per hour that will generate a pressure drop of 1 bar across the valve.*

1"	1 1/4"	1 1/2"	2"	2 1/2"	3"	4"
39	50	96	192	264	351	653

CURVA PRESIÓN TEMPERATURA / *PRESSURE TEMPERATURE RATING*

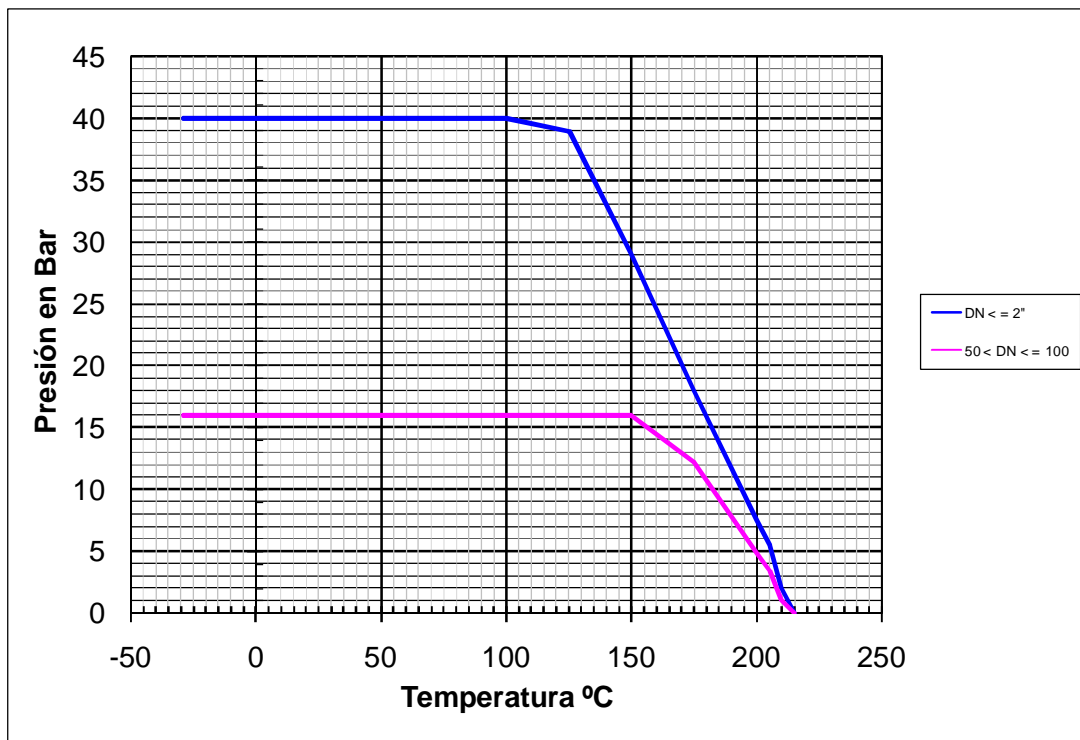

ARTICULO: 2541

Válvula de esfera de tres vías Tipo "T", extremos bridados Flanged Ends Three Way ball valve, Type "T"

Características

1. Válvula esfera tres vías paso total.
2. Configuración de Esfera en "T".
3. Extremos Bridados según EN 1092.
PN40 desde DN 25 hasta DN 50.
PN16 desde DN 65 hasta DN 100.
4. Construcción en acero inoxidable 1.4408 (CF8M).
5. Norma de diseño DIN 3357 / EN 12516-1.
6. Cuatro asientos PTFE + 15 % Fibra de Vidrio (otros materiales consultar).
7. Tórica de FKM (Viton) en el eje.
8. Dispositivo Anti-estático.
9. Sistema de bloqueo.
10. Montaje actuador directo s/ ISO 5211.
11. Eje inexpulsable.
12. Presión de trabajo máxima 16/40 bar, según medida.
13. Temperatura de trabajo -25 °C + 180 °C.

Features

1. Stainless steel full port ball valve.
2. "T" Ball configuration.
3. Flanges ends according to EN 1092.
PN40 from DN 25 to DN 50.
PN16 from DN 65 to DN 100.
4. Made of stainless steel 1.4408 (CF8M).
5. Design according to DIN 3357 / EN 12516-1.
6. Four Ball seats PTFE + 15 % G.F.
(please ask for other materials).
7. FKM (Viton) o'ring in the stem.
8. Anti-static device.
9. Locking system.
10. Direct mounting actuator according to ISO 5211.
11. Blow-out proof stem.
12. Max. working pressure 16/40 bar, according to size.
13. Working Temperature -25 °C + 180 °C.

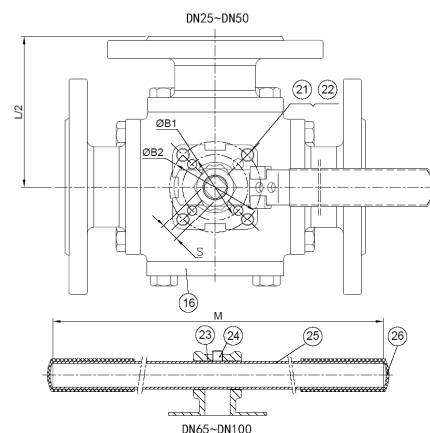
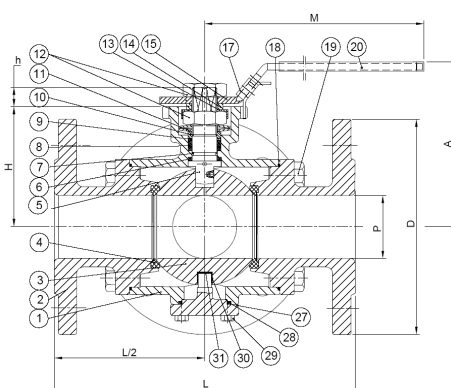

Nº	Denominación / Name	Material	Acabado Superficial / Surface Treatment	Cód. Recambio Spare Part Code
1	Cuerpo / Body	Acero Inox. / Stainless Steel 1.4408	Granallado / Shot blasting	-----
2	Tapa / Cap	Acero Inox. / Stainless Steel 1.4408	Granallado / Shot blasting	-----
3*	Bola / Ball	Acero Inox. / Stainless Steel 1.4408	-----	B2541
4*	Asiento / Ball Seat	PTFE + 15% F.V. / PTFE + 15% G.F.	-----	2928
5	Eje / Stem	Acero Inox. / Stainless Steel AISI 316	-----	-----
6*	Anillo Fricción / Thrust washer	PTFE	-----	2928
7*	Tórica / O' ring	FKM	-----	2928
8*	Empaquetadura / Stem packing	PTFE	-----	2928
9*	Casquillo / Bushing	Inox. + PTFE / S.S. + PTFE	-----	2928
10	Anillo Prensa / Gland	Acero Inox. / Stainless Steel AISI 316	-----	-----

Nº	Denominación / Name	Material	Acabado Superficial / Surface Treatment	Cód. Recambio Spare Part Code
11	Arandela Resorte / Spring Washer	Acero Inox. / Stainless Steel AISI 301	-----	-----
12	Tuerca vástago / Stem Nut	Acero Inox. / Stainless Steel AISI 304	-----	-----
13	Antigiro / Nut Locker	Acero Inox. / Stainless Steel AISI 304	-----	-----
14	Arandela / Washer	Acero Inox. / Stainless Steel AISI 304	-----	-----
15	Maneta / Handle (DN25-DN50)	Acero Inox. / Stainless Steel AISI 304	-----	-----
16	Tapa ciega / End Cap	Acero Inox. / Stainless Steel 1.4408	Granallado / Shot blasting	-----
17	Bloqueo maneta / Lock device (DN25-DN50)	Acero Inox. / Stainless Steel AISI 304	-----	-----
18*	Junta / Gasket	PTFE	-----	2928
19	Tornillo / Bolt	Acero Inox. / Stainless Steel AISI 304	-----	-----
20	Funda / Handle Sleeve	Vynil	-----	-----
21	Tornillo Tope / Stop Bolt	Acero Inox AISI 304 / SS 304	-----	-----
22	Tuerca / Nut	Acero Inox AISI 304 / SS 304	-----	-----
23	Adaptador Maneta / Handle Adapter (DN65-DN100)	Acero Inox AISI 304 / SS 304	Granallado / Shot blasting	-----
24	Tornillo / Bolt	Acero Inox AISI 304 / SS 304	-----	-----
25	Maneta / Handle	ASTM A 53	Cincado / Zn Plated	-----
26	Funda / Handle Sleeve	Vynil	-----	-----
27	Tapa Inferior / Bottom Cap	Acero Inox AISI 316 / SS 316	Granallado / Shot blasting	-----
28*	Junta / Gasket	PTFE	-----	2928
29	Tornillo / Bolt	Acero Inox AISI 304 / SS 304	-----	-----
30*	Casquillo / Bush	PTFE	-----	2928
31*	Disco / Disk	PTFE	-----	2928

* Piezas de recambio disponibles / Available spare parts

DIMENSIONES GENERALES / GENERAL DIMENSIONS

Ref.	Medida/ Size	PN	P	Dimensiones / Dimensions (mm)							ISO 5211 (ØB1/B2)	Peso / Weight (Kg)
				L	ØD	H	A	M	S	h		
2541 06	1"	40	25	180	115	68	99	175	11	11	F04/F05	8,600
2541 07	1 ¼"	40	32	190	140	72	103	175	11	11	F04/F07	11,800
2541 08	1 ½"	40	38	212	150	85	119	200	14	14	F05/F07	14,700
2541 09	2"	40	49	230	165	92	126	200	14	14	F05/F07	19,700
2541 10	2 ½"	16	63	290	185	107	172	400	17	17	F07/F10	33,300
2541 11	3"	16	75	310	200	119	187	400	17	18	F07/F10	47,100
2541 12	4"	16	99	350	220	150	214	400	22	22	F10	73,700

Dispositivo Antiestático / Anti-static Device

Este dispositivo nos garantiza la continuidad eléctrica entre esfera - eje - cuerpo, esto es de especial necesidad en fluidos inflamables / This device ensures the electrical continuity between Ball - Stem - Body, this is of special need in flammable fluids.

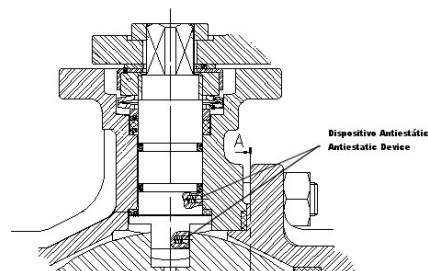

Configuraciones de flujo para válvula de tres vías “T – PORT “ giro 90°/ *Flow Patterns for “ T-PORT “ 3 way valves 90° turn.*

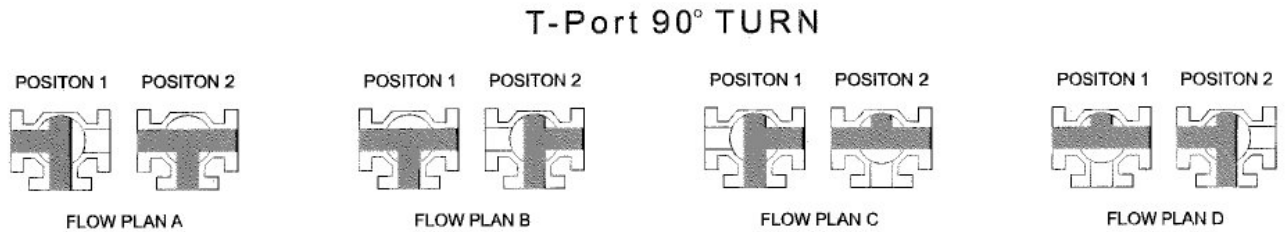

VALORES DE Kv / Kv VALUES

K_v (m^3/h) = Es la cantidad de metros cúbicos por hora que pasará a través de la válvula generando una pérdida de carga de 1 bar.

K_v (m^3/h) = *Flow rate of water in cubic meter per hour that will generate a pressure drop of 1 bar across the valve.*

1"	1 1/4"	1 1/2"	2"	2 1/2"	3"	4"
39	50	96	192	264	351	653

CURVA PRESIÓN TEMPERATURA / *PRESSURE TEMPERATURE RATING*

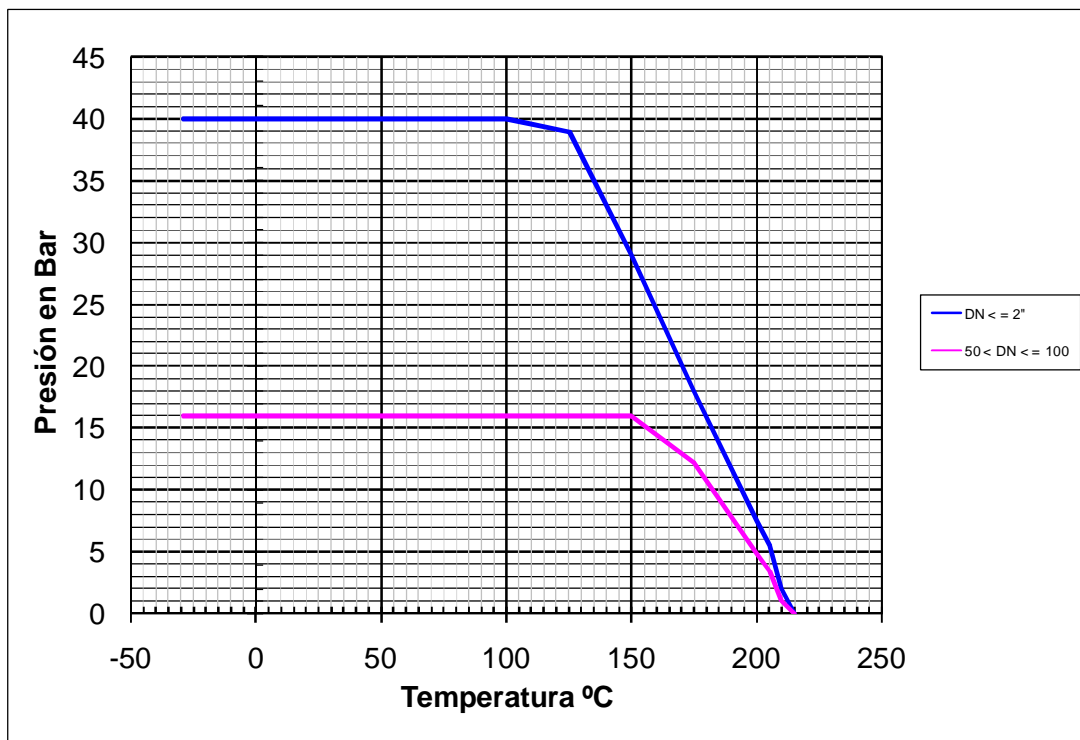



CONDICIONES DE TRABAJO

- 1. Fluidos de accionamiento**
Aire seco o lubricado, gases no corrosivos.
- 2. Presión de suministro de aire**
Doble acción: 2 ÷ 8 Bar;
Simple acción: 2 ÷ 8 Bar
- 3. Temperatura de funcionamiento**
Standard: de -20°C +80°C
- 4. Recorrido del ajuste**
Tiene un rango de ajuste de $\pm 5^\circ$ para la rotación en 90°
- 5. Lubricación**
No necesita lubricante en condiciones normales de trabajo
- 6. Aplicación**
Cualquiera interior o exterior
- 7. Presión máxima**
La presión máxima de entrada debe ser de 8 bar

OPERATING CONDITIONS

- 1. Operating media**
Dry or lubricated air, non-corrosive gases.
- 2. Air supply pressure**
*Double acting: 2 ÷ 8 Bar;
Spring return: 2 ÷ 8 Bar*
- 3. Operating temperature**
Standard: -20°C+80°C
- 4. Travel adjustment**
Have adjustment range of $\pm 5^\circ$ for the rotation at 90°
- 5. Lubrication**
Under normal operating conditions, no lubricant is needed.
- 6. Application**
Either indoor or outdoor
- 7. Highest pressure**
The maximum input pressure is 8 Bar

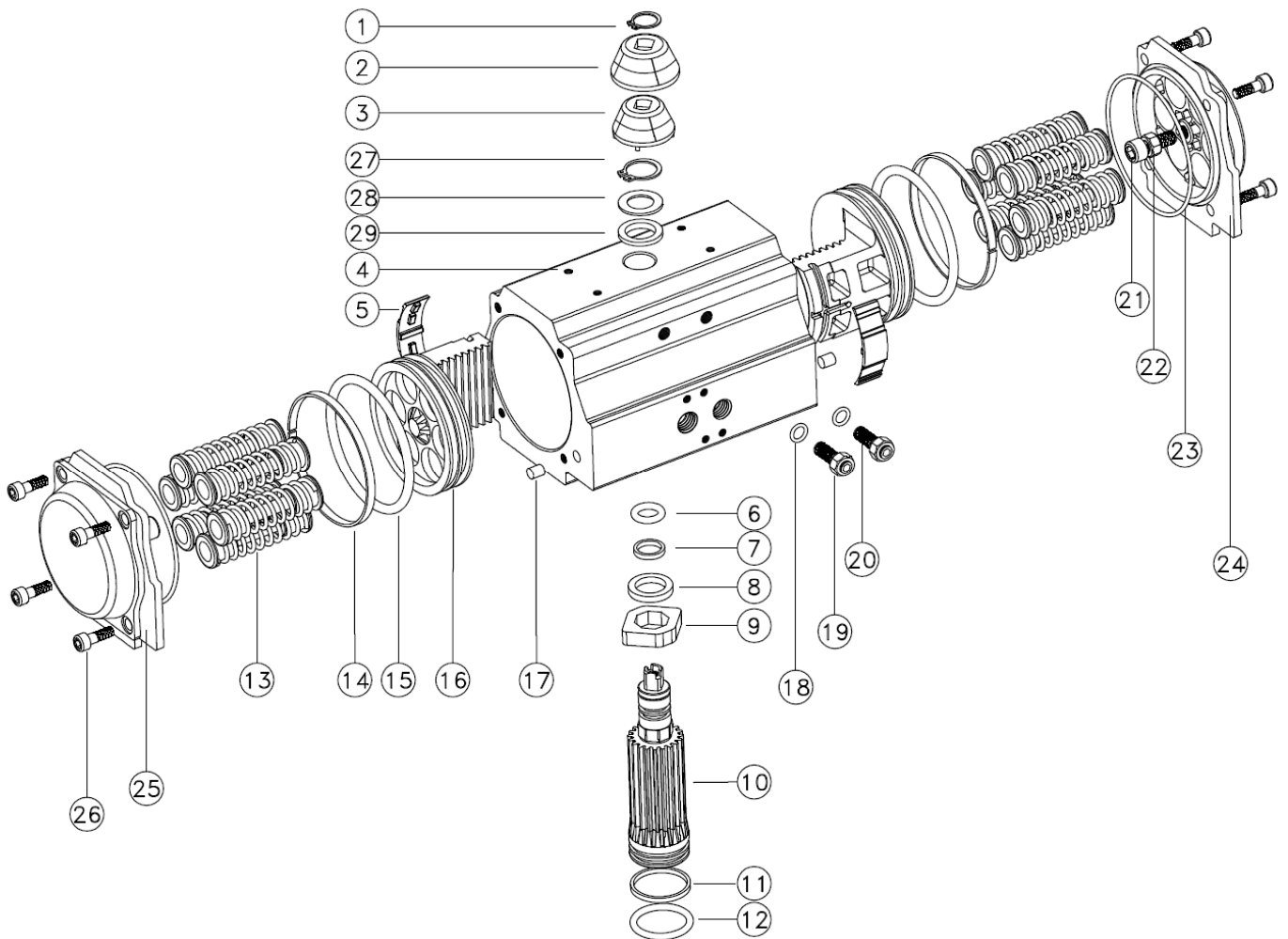

Nº	Denominación	Name	Qty	Material	Material	Protección
1	Anillo Seeger	<i>Spring clip</i>	1	AISI 304	<i>Stainless Steel</i>	
2	Carcasa indicador	<i>Housing indicator</i>	1	PC+ABS	<i>Plastic</i>	
3	Indicador	<i>Indicator</i>	1	PC+ABS	<i>Plastic</i>	
4	Cuerpo	<i>Body</i>	1	Al 6005-T5	<i>Extruded aluminium alloy</i>	<i>Anodized + painted</i>
5	Guía Pistón	<i>Guide piston</i>	2	Tecnopolímero	<i>POM</i>	
6	O-ring superior	<i>O-ring (pinion top)</i>	1	NBR	<i>NBR</i>	
7	Anillo superior	<i>Washer (pinion top)</i>	1	Tecnopolímero	<i>POM</i>	
8	Separador	<i>Bearing (pinion top)</i>	1	Tecnopolímero	<i>POM</i>	
9	Leva	<i>Cam</i>	1	Al. Acero	<i>Alloy steel</i>	
10	Piñón	<i>Pinion</i>	1	Al. Acero	<i>Alloy steel</i>	<i>Nickel plated</i>
11	Anillo inferior	<i>Bearing (pinion bottom)</i>	1	Tecnopolímero	<i>POM</i>	
12	O-ring inferior	<i>O-ring (pinion bottom)</i>	1	NBR	<i>NBR</i>	
13	Muelle	<i>Spring</i>	0-12	AISI 301	<i>Stainless Steel</i>	
14	Anillo pistón	<i>Ring (Piston)</i>	2	Tecnopolímero	<i>POM</i>	
15	O-ring pistón	<i>O-ring (Piston)</i>	2	NBR	<i>NBR</i>	
16	Pistón	<i>Piston</i>	2	Al. A380.1	<i>Cast aluminium</i>	<i>Anodized /galvanized</i>
17	Tapón	<i>Plug</i>	2	NBR	<i>NBR</i>	
18	O-ring	<i>O-ring</i>	2	NBR	<i>NBR</i>	
19	Tuerca	<i>Adjust Nut</i>	2	AISI 304	<i>Stainless Steel</i>	
20	Prisionero	<i>Adjust screw</i>	2	AISI 304	<i>Stainless Steel</i>	
21	Tornillo tope	<i>Stop screw</i>	2	AISI 304	<i>Stainless Steel</i>	
22	Tuerca tope	<i>Nut (stop screw)</i>	2	AISI 304	<i>Stainless Steel</i>	
23	O-ring tapa	<i>O-ring (End cap)</i>	2	NBR	<i>NBR</i>	
24	Tapa derecha	<i>End cap right</i>	2	Al. A380.1	<i>Cast aluminium</i>	<i>Anodized + painted</i>
25	Tapa izquierda	<i>End cap left</i>	2	Al. A380.1	<i>Cast aluminium</i>	<i>Anodized + painted</i>
26	Tornillo tapa	<i>Cap screw</i>	8	AISI 304	<i>Stainless Steel</i>	
27	Anillo Seeger	<i>Spring clip</i>	1	AISI 304	<i>Stainless Steel</i>	
28	Arandela	<i>Washer</i>	1	AISI 304	<i>Stainless Steel</i>	
29	Separador	<i>Ring</i>	1	Tecnopolímero	<i>POM</i>	

PIEZAS QUE COMPONEN EL KIT DE REPARACION / REPAIR KIT PARTS.

DIMENSIONES

DIMENSIONS



TABLA DE DIMENSIONES

DIMENSIONS TABLE

Model	A	B	C	D	E	F	G	H	I	J	K	L	M	N	Z	Ø	Air Connection
GNP14	28.5	36.5	60	-	90	52	30	80	(Φ36)*	(Φ42)*	M5	M5	11	14	122	Φ 55	NAMUR G1/4"
GNP24	30	41.5	65.5	72	102	65	30	80	(Φ36)*	(Φ42)*	M5	M5	11	14	147	Φ 55	NAMUR G1/4"
GNP44	36	47	81	87.5	117.5	72	30	80	(Φ42)*	(Φ50/Φ70)*	M5	M6/M8	14	18	168	Φ 55	NAMUR G1/4"
GNP60	42	53	94	99.5	129.5	81	30	80	Φ50	Φ70	M6	M8	14	18	184	Φ 55	NAMUR G1/4"
GNP94	46	57	98.5	108.7	138.7	92	30	80	Φ50	Φ70	M6	M8	17	21	204	Φ 55	NAMUR G1/4"
GNP135	50	58.5	111	116.8	146.8	98	30	80	Φ50	Φ70	M6	M8	17	21	262	Φ 55	NAMUR G1/4"
GNP198	57.5	64	122.5	133	163	109.5	30	80	Φ70	Φ102	M8	M10	22	26	268	Φ 55	NAMUR G1/4"
GNP300	67.5	74.5	145.5	155	185	127.5	30	80	Φ70	Φ102	M8	M10	22	26	296	Φ 80	NAMUR G1/4"
GNP513	75	77	160.7	171.5	201.5	137.5	30	80	Φ102	Φ125	M10	M12	27	31	390	Φ 80	NAMUR G1/4"
GNP800	87	87	184	197	227	158	30	80	Φ102	Φ125	M10	M12	27	31	454	Φ 80	NAMUR G1/4"
GNP1280	103	103	216	230	270	189	30	80/130	(Φ125)*	(Φ140)*	M12	M16	36	40	525	Φ 80	NAMUR G1/4"
GNP1600	113	113	235.5	255	295	210	30	80/130		Φ140		M16	36	40	532	Φ 91	NAMUR G1/4"
GNP2300	130	130	264	288	328	245	30	80/130		Φ140		M16	46	50	610	Φ 91	NAMUR G1/4"
GNP2500	147	147	299	326	366	273	30	80/130		Φ165		M20	46	50	722	Φ 91	NAMUR G1/4"

(*) debe elegirse una de las dos opciones / must choose one of two options

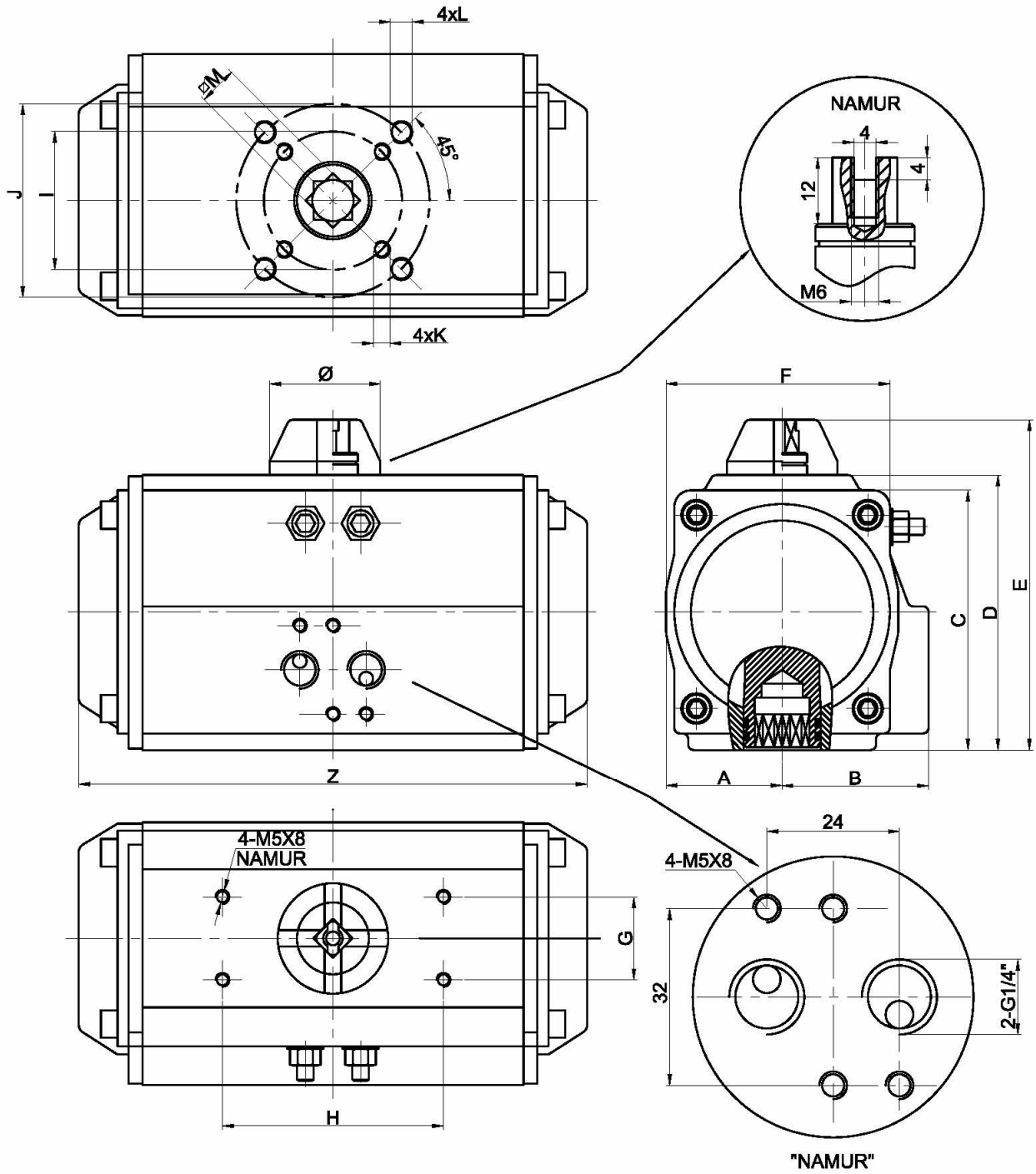
CONSUMO DE AIRE

AIR CONSUMPTION

Model	Volume opening	Volume closing	Model	Volume opening	Volume closing
GNP 14	0.08	0.11	GNP 300	1.60	1.40
GNP 24	0.12	0.16	GNP 513	2.5	2.2
GNP 44	0.21	0.23	GNP 800	3.7	3.2
GNP 60	0.30	0.34	GNP 1280	5.9	5.4
GNP 94	0.43	0.47	GNP 1600	7.5	7.5
GNP 135	0.64	0.73	GNP 2300	11.0	9.0
GNP 198	0.95	0.88	GNP 2500	17.0	14.0

El aire consumido depende de la presión, del volumen y del tiempo del ciclo y se calcula como sigue:

$I/min = \text{Volumen de aire (Volumen de aire Abriendo + Volumen de aire Cerrando)} \times [(Presión de aire alimentación (Kpa)+101.3) / 101.3] \times \text{Tiempo duración del ciclo (}/min)$

Air consumption depends on Air Supply. Air volume and Action cycle times, the calculating as follows

$I/min = \text{Air volume (Air volume Opening + Air volume closing)} \times [(Air Supply (Kpa)+101.3) / 101.3] \times \text{Action cycle times (}/min)$

PARES ACTUADORES DOBLE EFECTO / DOUBLE ACTING ACTUATORS TORQUES

Modelo/Model	Presión alimentación de aire / Air supply pressure (Unit Bar)									
	2	2.5	3	4	4.5	5	5.5	6	7	8
GNP 14	4.8	6.0	7.2	9.5	10.7	11.9	13.1	14.3	16.7	19.1
GNP 24	8.0	10.0	12.0	16.0	18.0	20.0	21.9	23.9	27.9	31.9
GNP 44	14.6	18.2	21.9	29.2	32.8	36.5	40.1	43.8	51.1	58.4
GNP 60	20.1	25.1	30.1	40.1	45.1	50.2	55.2	60.2	70.2	80.3
GNP 94	31.4	39.2	47.0	62.7	70.5	78.4	86.2	94.1	109.7	125.4
GNP 135	45.1	56.4	67.7	90.3	101.6	112.9	124.1	135.4	158.0	180.6
GNP 198	66.1	82.7	99.2	132.2	148.8	165.3	181.8	198.4	231.4	264.5
GNP 300	100.3	125.4	150.5	200.6	225.7	250.8	275.9	301.0	351.1	401.3
GNP 513	171.0	213.8	256.5	342.0	384.8	427.5	470.3	513.0	598.5	684.0
GNP 800	266.0	332.5	399.0	532.0	598.5	665.0	731.5	798.0	931.0	1064.0
GNP 1280	425.6	532.0	638.4	851.2	957.6	1064.0	1170.4	1276.8	1489.6	1702.4
GNP 1600	532.0	665.0	798.0	1064.0	1197.0	1330.0	1463.0	1596.0	1862.0	2128.0
GNP 2300	769.5	961.9	1154.3	1539.0	1731.4	1923.8	2116.1	2308.5	2693.3	3078.0
GNP 2500	1169.6	1462.1	1754.5	2339.3	2631.7	2924.1	3216.5	3508.9	4093.7	4678.6

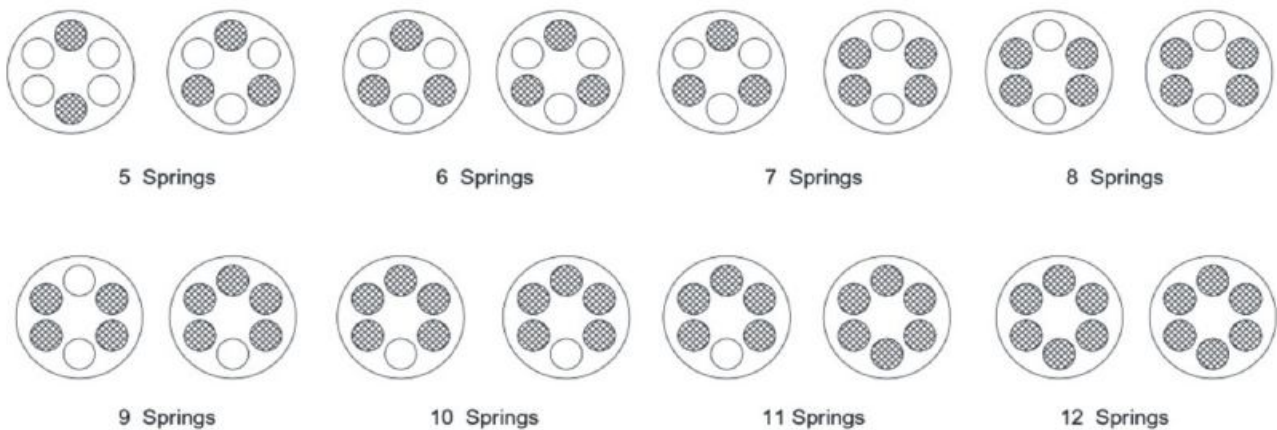

PARES ACTUADORES SIMPLE EFECTO / SPRING RETURN ACTUATORS TORQUES

TIPO/ TYPE	Cantidad de muelles /Spring Qty	PRESIÓN DE AIRE DE ENTRADA EN BAR / AIR SUPPLY IN BAR														Spring output/ Obtenido por muelle		
		2,5		3		4		5		6		7		8		90°	0°	
		0°	90°	0°	90°	0°	90°	0°	90°	0°	90°	0°	90°	0°	90°			
GNP 24S	3 + 2	5.7	3.8	7.6	5.7												6.2	4.3
	3 + 3	4.9	2.5	6.9	4.5	10.9	8.5										7.4	5.0
	4 + 3	4.0	1.3	6.0	3.3	9.8	7.3	14.0	10.4								8.6	5.9
	4 + 4			5.2	2.0	9.2	6.0	13.2	9.1	17.2	14.1						9.9	6.7
	5 + 4			4.3	0.8	8.3	4.8	12.3	7.9	16.3	12.8	20.3	16.8				11.1	7.6
	5 + 5					7.4	3.6	11.5	6.7	15.5	11.6	19.5	15.6				12.4	8.5
	6 + 5					6.6	2.3	10.6	5.4	14.6	10.4	18.6	14.3	22.6	18.3		13.6	9.3
6 + 6							9.7	4.2	13.8	9.1	17.8	12.2	21.8	17.1		14.8	10.2	
GNP 44S	3 + 2	11.4	7.7	15.0	11.4	22.3	14.9										10.4	6.8
	3 + 3	10.1	5.7	13.6	9.3	20.9	16.6	28.3	23.9								12.5	8.2
	4 + 3	8.6	3.6	12.5	7.2	19.5	14.5	26.8	21.9								14.6	9.6
	4 + 4			10.9	5.1	18.2	12.4	25.5	19.8	32.8	27.0	40.1	34.3				16.7	10.9
	5 + 4					16.8	10.4	24.1	17.7	31.4	24.9	38.7	32.3				18.8	12.3
	5 + 5					1.4	8.2	22.8	15.6	30.0	22.8	37.3	30.1	44.7	37.4		20.9	13.7
	6 + 5							21.5	13.5	28.7	20.7	36.0	28.0	43.3	35.3		22.9	15.0
6 + 6							20.0	11.4	27.3	18.6	34.6	25.9	41.9	33.3		25.0	16.4	
GNP 60S	3 + 2	14.5	10.6	19.4	15.5	29.5	25.7										14.5	10.5
	3 + 3	12.4	7.6	17.3	12.6	27.4	22.7	37.5	32.8								17.4	12.7
	4 + 3	10.4	4.8	15.2	9.7	25.3	19.6	35.4	29.9								20.3	14.8
	4 + 4			13.1	6.8	23.1	16.9	33.3	27.0	43.2	37.0	53.3	47.0				23.2	16.9
	5 + 4					21.0	14.1	31.2	24.1	41.1	34.1	51.2	44.2				26.1	19.0
	5 + 5					19.0	11.1	28.8	21.2	39.0	31.2	49.1	41.2	59.1	51.2		29.0	21.1
	6 + 5							27.0	8.3	37.0	28.3	47.0	38.4	57.0	48.4		31.9	23.2
6 + 6							24.9	15.4	34.9	25.4	44.9	35.4	54.9	45.4		34.7	25.3	
GNP 94S	3 + 2	23.3	16.1	31.1	24.0	46.8	39.7										23.0	15.8
	3 + 3	20.1	11.5	28.0	19.3	43.7	35.1	59.4	50.7								27.6	19.0
	4 + 3	17.0	6.9	24.8	14.8	40.5	30.5	56.2	46.2								32.2	22.1
	4 + 4			21.7	10.1	37.4	25.8	53.1	41.5	68.8	57.2	84.5	72.9				36.8	25.3
	5 + 4					34.2	21.3	49.9	37.0	65.6	52.6	81.2	68.3				41.4	28.5
	5 + 5					31.0	16.6	46.7	32.3	62.4	48.0	78.1	63.7	93.8	79.3		46.0	31.6
	6 + 5							43.6	27.7	59.3	43.4	75.0	59.1	90.6	74.8		50.6	34.8
6 + 6							40.4	23.2	56.1	38.9	71.7	54.5	87.4	70.2		55.2	38.0	
GNP 135S	3 + 2	33.1	22.0	44.2	33.2	66.8	55.9										34.4	23.3
	3 + 3	28.4	15.2	39.6	26.4	62.2	49.0	84.4	71.6								41.2	28.0
	4 + 3	23.8	8.2	34.9	19.4	57.5	42.1	80.2	64.7								48.1	32.7
	4 + 4			31.3	12.6	52.9	35.2	75.5	57.9	98.1	80.5	120.7	103.0				55.0	37.3
	5 + 4					48.2	28.4	70.9	51.0	93.5	73.6	116.0	96.1				61.9	42.0
	5 + 5					43.6	21.5	66.2	44.1	88.8	66.7	111.3	89.2	134.0	111.8		68.7	46.7
	6 + 5							61.5	37.2	84.1	59.9	106.6	82.4	129.2	105.0		75.6	51.4
6 + 6							56.8	30.4	79.4	53.0	101.9	75.5	124.5	98.1		82.5	56.0	
GNP 198S	3 + 2	51.0	33.4	67.5	49.9	100.6	83.0										49.2	31.6
	3 + 3	44.7	23.5	61.1	40.0	94.2	73.2	127.3	106.2								59.1	38.0
	4 + 3	38.4	13.7	54.9	30.3	87.9	63.4	121.0	96.4								68.9	44.3
	4 + 4			48.5	20.4	81.6	53.5	114.7	86.5	147.7	119.6	180.8	152.7				78.7	50.6
	5 + 4					75.3	43.7	108.4	76.8	141.5	109.8	174.5	142.9				88.6	56.9
	5 + 5					68.9	33.4	102.0	66.5	136.1	99.6	168.2	132.6	201.2	165.7		98.4	63.3
	6 + 5							95.7	57.0	128.7	90.1	161.8	123.1	194.8	156.2		108.3	69.6
6 + 6							89.4	47.5	122.5	80.6	155.5	113.6	188.6	146.7		118.1	75.9	
GNP 300S	3 + 2	73	47	98	72	148	122										79	52
	3 + 3	63	31	88	56	138	107	188	157								94	63
	4 + 3	52	15	77	40	127	90	178	141								110	73
	4 + 4			67	25	117	75	167	125	217	176	268	226				125	84
	5 + 4					107	59	157	109	207	159	257	210				141	94
	5 + 5					96	44	146	94	196	144	247	194	297	245		157	105
	6 + 5							136	78	186	128	236	178	286	228		173	115
6 + 6							125	63	176	113	226	163	276	213		188	125	

TIPO/ TYPE	Cantidad de muelles /Spring Qty	PRESIÓN DE AIRE DE ENTRADA EN BAR / AIR SUPPLY IN BAR														Spring output/ Obtenido por muelle		
		2,5		3		4		5		6		7		8				
		0°	90°	0°	90°	0°	90°	0°	90°	0°	90°	0°	90°	0°	90°	90°	0°	
GNP 513S	3 + 2	128	85	171	127	256	213										129	86
	3 + 3	111	59	154	102	239	187	325	273								155	103
	4 + 3	94	33	137	76	222	162	308	247								181	120
	4 + 4			120	50	205	136	291	221	376	307	462	392				206	137
	5 + 4					187	110	273	196	358	281	444	367				232	155
	5 + 5					170	84	256	169	341	255	427	340	512	426		258	172
	6 + 5							238	143	324	229	409	314	495	400		284	189
	6 + 6							221	118	307	203	392	289	478	374		310	206
GNP 800S	3 + 2	193	124	259	191	392	324										208	140
	3 + 3	165	83	232	149	365	282	498	415								250	168
	4 + 3	137	41	203	107	336	240	469	373								292	196
	4 + 4			176	66	309	199	442	237	575	465	708	598				333	223
	5 + 4					280	157	413	290	546	423	679	556				375	251
	5 + 5					253	115	386	248	519	381	652	514	785	647		417	279
	6 + 5							358	207	491	340	624	473	757	606		458	307
	6 + 6							330	165	463	298	596	431	729	564		500	335
GNP 1280S	3 + 2	332	222	438	329	651	542										309	200
	3 + 3	292	161	398	267	611	480	824	693								371	240
	4 + 3	252	99	358	205	571	418	784	631								433	280
	4 + 4			318	143	531	356	744	569	957	782	1169	995				495	320
	5 + 4					491	295	704	507	917	720	1130	933				557	360
	5 + 5					451	233	664	446	877	658	1090	871	1302	1084		618	400
	6 + 5							624	384	837	597	1050	809	1263	1022		680	440
	6 + 6							584	322	797	535	1010	748	1223	960		742	480
GNP 1600S	3 + 2	390	285	52	418	789	684										380	275
	3 + 3	335	209	468	342	734	608	1000	874								456	330
	4 + 3	280	133	413	266	679	532	945	798								532	385
	4 + 4			358	190	624	456	890	722	1156	988	1422	1254				608	440
	5 + 4					569	380	835	646	1101	912	1367	1178				684	495
	5 + 5					514	304	780	570	1046	836	1312	1102	1578	1368		760	550
	6 + 5							725	494	991	760	1257	1026	1523	1292		836	605
	6 + 6							670	418	936	684	1202	950	1468	1216		912	660
GNP 2300S	3 + 2	552	409	744	600	1129	985										554	410
	3 + 3	470	297	662	489	1047	874	1432	1259								665	492
	4 + 3	388	187	580	379	964	764	1349	1149								775	575
	4 + 4			498	268	883	653	1267	1037	1652	1422	2037	1807				886	656
	5 + 4					800	542	1185	926	1569	1311	1954	1696				998	739
	5 + 5					718	431	1103	816	1488	1201	1872	1586	2257	1970		1108	821
	6 + 5							1021	705	1408	1090	1791	1474	2176	1859		1219	903
	6 + 6							939	594	1323	979	1708	1363	2093	1748		1330	985
GNP 2500S	3 + 2	903	675	1195	968	1779	1552										787	560
	3 + 3	790	519	1083	811	1667	1396	2252	1981								943	672
	4 + 3	679	361	972	654	1556	1238	2141	1823								1101	783
	4 + 4			860	497	1444	1081	2029	1666	2614	2252	3199	2836				1258	895
	5 + 4					1332	923	1917	1509	2502	2094	3087	2678				1416	1007
	5 + 5					1220	767	1806	1352	2390	1937	2974	2521	3560	3107		1572	1119
	6 + 5							1693	1194	2278	1779	2862	2364	3448	2949		1730	1231
	6 + 6							1582	1037	2167	1623	2751	2207	3336	2792		1887	1342