

ARTICULO: 2118

Válvula de esfera paso total tipo Wafer Acero Inoxidable Stainless steel full port ball valve, Wafer Type

Características

1. Válvula esfera paso total tipo wafer.
2. Montaje entre bridas EN 1092 PN16.
3. Construcción en acero inox. 1.4408 (CF8M).
4. Asientos PTFE + 15 % F.V.
(otro material consultar)
5. Tórica en el eje de FKM (Viton).
6. Vástago Inexpulsable.
7. Montaje actuador directo según ISO 5211.
8. Sistema de bloqueo incorporado.
9. Presión de trabajo máxima 16 bar.
10. Temperatura de trabajo $-20\text{ }^{\circ}\text{C} + 180\text{ }^{\circ}\text{C}$.

Features

1. Full port ball valve, Wafer type.
2. Assembly between flanges EN 1092 PN16.
3. Made of stainless steel 1.4408 (CF8M).
4. Ball seats PTFE + 15 % FG.
(please ask for other materials)
5. O'ring in the stem FKM (Viton).
6. Blow – out proof stem.
7. Direct mounting actuator acc. to ISO 5211.
8. Block System included.
9. Max. Working pressure 16 bar.
10. Working Temperature $-20\text{ }^{\circ}\text{C} + 180\text{ }^{\circ}\text{C}$.

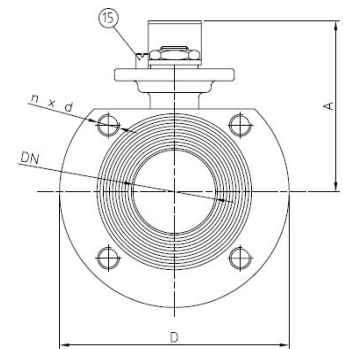
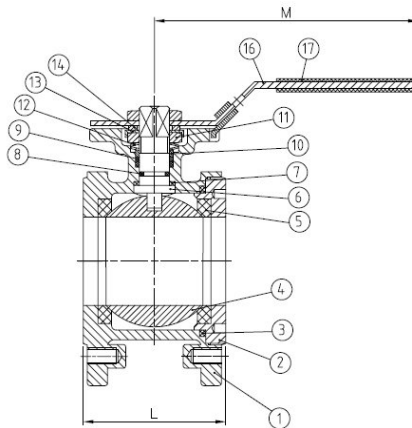

Nº	Denominación / Name	Material	Acabado Superficial / Surface Treatment	Cód. Recambio Spare Part Code
1	Cuerpo / Body	Acero Inox. / Stainless Steel 1.4408	Decapado / Shot Blasting + Pickling	-----
2	Tapón / Plug	Acero Inox. / Stainless Steel 1.4408	Decapado / Shot Blasting + Pickling	-----
3*	Juntas / Gasket	PTFE	-----	2818
4	Bola / Ball	Acero Inox. / Stainless Steel 1.4408	-----	-----
5*	Asiento / Ball Seat	PTFE + 15 % F.V. / PTFE + 15 % FG	-----	2818
6	Eje / Stem	Acero Inox. AISI 316 / SS 316	-----	-----
7*	Arandela / Thrust Washer	PTFE	-----	2818
8*	Tórica / O-ring	FKM	-----	2818
9*	Empaquetadura / Packing	PTFE	-----	2818
10	Prensa / Gland	Acero Inox AISI 304 / S.S. 304	-----	-----

11	Tuerca / Nut	Acero Inox AISI 304 / S.S. 304	-----	-----
12	Arandela Resorte / Spring washer	Acero Inox AISI 304 / S.S. 304	-----	-----
13	Antigiro / Lock Washer	Acero Inox AISI 304 / S.S. 304	-----	-----
14	Arandela / Washer	Acero Inox AISI 304 / S.S. 304	-----	-----
15	Tope / Stop Pin	Acero Inox AISI 304 / S.S. 304	-----	-----
16	Maneta / Handle	Acero Inox AISI 304 / S.S. 304	-----	-----
17	Funda / Plastic Cover	Vynil	-----	-----

* Piezas de recambio disponibles / Available spare parts

Detalle de la zona de Eje / Stem detail

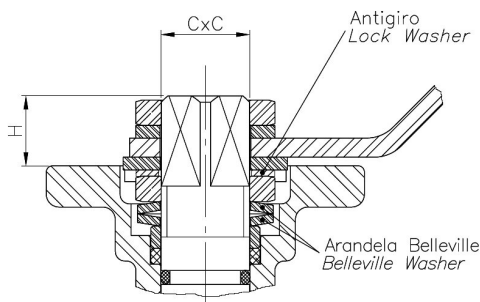

Antigiro / Lock Washer: Previene el desajuste de la tuerca del eje en elevados ciclos de maniobra / Prevents unthreading of stem nut in high cycle automation applications.

Arandela Belleville / Belleville Washer: Las arandelas belleville proporcionan una carga constante sobre el prensa asegurando un cierre firme en variaciones de condiciones de trabajo. / Standard belleville washers provide constant "live load" on the stem seals, assuring a tight seal even varying service parameters.

DIMENSIONES GENERALES / GENERAL DIMENSIONS

Ref.	DN	PN	Assembly Holes (n x d)	Dimensiones / Dimensions (mm)				Peso / Weight (Kg)
				ØD	A	L	M	
2118 04	15	16	4 x M12	95	85	36	115	1,700
2118 05	20	16	4 x M12	105	90	38	115	1,900
2118 06	25	16	4 x M12	115	95	50	170	2,500
2118 07	32	16	4 x M16	140	100	53	170	3,500
2118 08	40	16	4 x M16	150	105	65	210	4,350
2118 09	50	16	4 x M16	165	115	78	210	5,450
2118 10	65	16	4 x M16	185	130	98	260	7,800
2118 11	80	16	8 x M16	200	145	118	260	10,300
2118 12	100	16	8 x M16	220	175	140	260	18,000

Ref.	Medida/ Size	PN	Dimensiones / Dimensions (mm)		
			H	C x C	ISO 5211
2118 04	1/2"	16	10	9 x 9	F03 / F04
2118 05	3/4"	16	10	9 x 9	F03 / F04
2118 06	1"	16	10	11 x 11	F04 / F05
2118 07	1 1/4"	16	12.5	11 x 11	F04 / F05
2118 08	1 1/2"	16	14.5	14 x 14	F05 / F07
2118 09	2"	16	14	14 x 14	F05 / F07
2118 10	2 1/2"	16	17	17 x 17	F07 / F10
2118 11	3"	16	16	17 x 17	F07 / F10
2118 12	4"	16	19	17 x 17	F07 / F10

CURVA PRESION TEMPERATURA / PRESSURE TEMPERATURE RATING

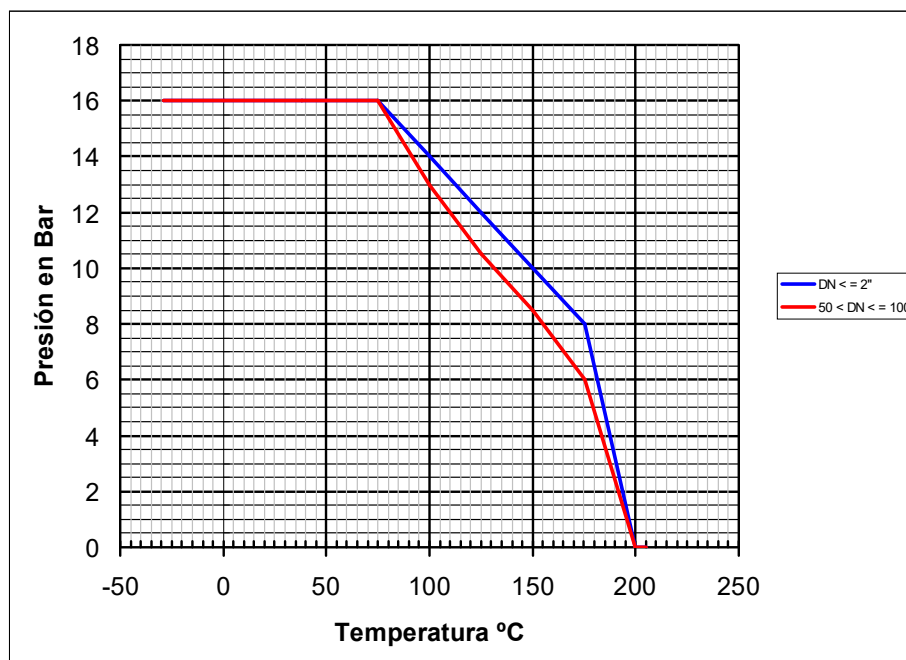

VALORES DE Kv / Kv VALUES

Kv = Es la cantidad de metros cúbicos por hora (m³/h) que pasará a través de la válvula generando una pérdida de carga de 1 bar.

Kv = Flow rate of water in cubic meter per hour (m³/h) that will generate a pressure drop of 1 bar across the valve.

1/2"	3/4"	1"	1 1/4"	1 1/2"	2"	2 1/2"	3"	4"
24	43	83	130	205	340	520	1100	1820