

ARTICULO: 2101

Válvula de mariposa tipo wafer. Fundición nodular + PTFE Butterfly valve wafer type. Ductile Iron + PTFE

Características	Features
1. Válvula de mariposa tipo wafer.	1. Butterfly valve wafer type.
2. Cuerpo bipartido de fundición nodular EN-GJS-400 (GGG-40) para montaje entre bridas ANSI 150 y EN 1092 PN 10/16.	2. Ductile iron EN-GJS-400 (GGG-40) split body allows installation between ANSI 150 and EN 1092 PN 10/16 pipe flanges.
3. Asiento de PTFE con base de EPDM.	3. PTFE body seat on EPDM backseat.
4. Disco de Acero Inoxidable 1.4408 (CF8M) pulido.	4. Butterfly disc of Stainless Steel 1.4408 (CF8M) polished.
5. Eje Inoxidable AISI 316.	5. Stem made of AISI 316.
6. Brida montaje actuadores según ISO 5211.	6. Actuator mounting plate according to ISO 5211.
7. Longitud entre caras según EN 558-1 Serie 20 (DIN 3202 K1).	7. Face to face according to EN 558-1 Series 20 (DIN 3202 K1).
8. Máxima presión de trabajo 10 bar.	8. Max. working pressure 10 bar.
9. Temperatura de trabajo -25°C + 180°C.	9. Working Temperature -25°C +180 °C.

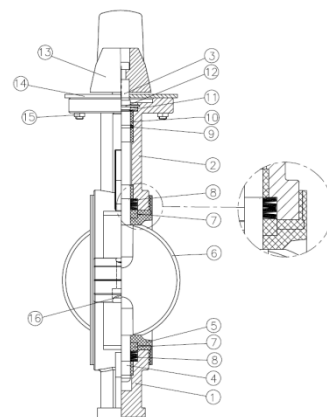

Nº	Denominación / Name	Material	Acabado Superficial / Surface Treatment	Cód. Recambio Spare Part Code
1	Cuerpo Inferior / Downside Body	Fund. nodular / Ductile Iron EN-GJS-400	Epoxy	-----
2	Cuerpo Superior / Upside Body	Fund. nodular / Ductile Iron EN-GJS-400	Epoxy	-----
3	Eje Superior / Upside Stem	Acero Inox. / Stainless Steel AISI 316	-----	-----
4	Eje Inferior / Downside Stem	Acero Inox. / Stainless Steel AISI 316	-----	-----
5 *	Asiento / Seat	PTFE c/base EPDM / PTFE on EPDM	-----	ET2101
6	Disco / Disc	Acero Inox. / Stainless Steel 1.4408	Pulido / Polished	-----
7	Buje / Hub	Nylon	-----	-----
8	Arandelas Muelle / Spring washer	Acero / Steel	Dacromet	-----
9	Tórica / O'ring	FKM	-----	-----
10	Casquillo / Bush	RPTFE	-----	-----
11	Arandela / Washer	Acero / Steel	Galvanizado / Galvanized	-----
12	Arandela Seeger / Seeger ring	Acero / Steel	Galvanizado / Galvanized	-----
13	Maneta / Handle	Aluminio / Aluminium	Epoxy	-----
14	Plato / Plate	Acero / Steel	Galvanizado / Galvanized	-----
15	Tornillo-Tuerca / Screw-Nut	Acero / Steel	Galvanizado / Galvanized	-----
16	Tornillo / Screw	Acero / Steel	Galvanizado / Galvanized	-----

* Piezas de recambio disponibles / Available spare parts

DIMENSIONES GENERALES / GENERAL DIMENSIONS:

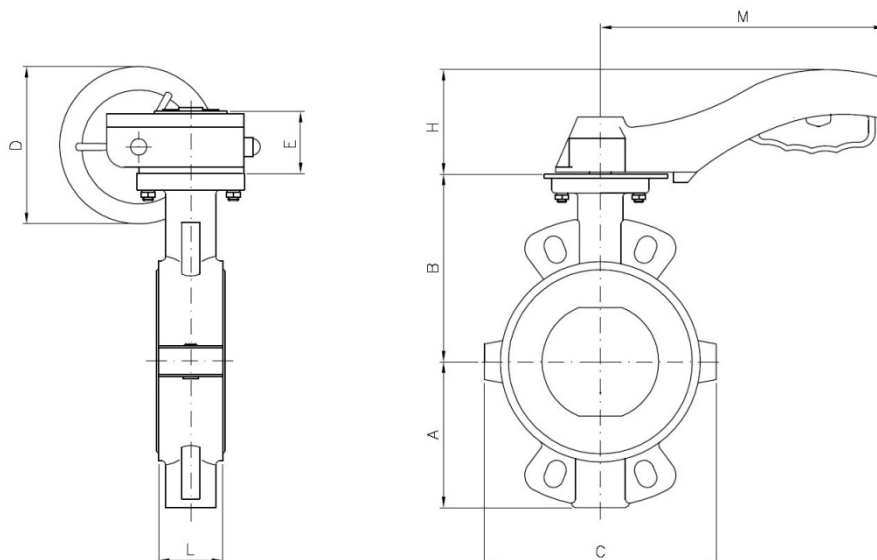

Ref	Medida/ Size	DN	PN	Dimensiones / Dimensions (mm)								Peso / Weight (Kg)
				L	A	B	C	D	E	H	M	
2101 09	2"	50	10	43	80	140	119	***	***	65	172	2,900
2101 10	2 ½"	65	10	46	89	150	131	***	***	65	172	3,180
2101 11	3"	80	10	46	95	158	145	***	***	65	172	3,550
2101 12	4"	100	10	52	114	176	180	***	***	78	264	5,530
2101 13	5"	125	10	56	127	190	202	***	***	78	264	6,875
2101 14	6"	150	10	56	139	210	230	150	72	***	***	8,250
2101 16	8"	200	10	60	175	236	295	300	85	***	***	17,400

*** Nota: A partir de 6" (DN 150), operación mediante reductor manual.

*** Note: From 6" (DN 150), handling by gear operator.

Dimensiones de la brida superior / Top flange dimensions:

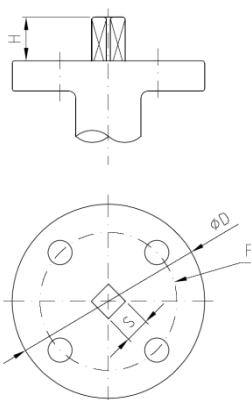

Dimensiones brida Superior / Top flange dimensions				
Ref.	F (ISO 5211)	S	D	H
2101 09	F05	11	70	26
2101 10	F05	11	70	26
2101 11	F05	11	70	26
2101 12	F07	14	90	29
2101 13	F07	14	90	29
2101 14	F07	14	90	32
2101 16	F10	17	125	38

Perdidas de Carga (Kv) según posición del disco / Head losses (Kv) according to disc position:

DN	Posición del Disco (grados) / Disc Position (degrees)								
	90°	80°	70°	60°	50°	40°	30°	20°	10°
50	125	99	73	53	37	23	14	6	1
65	244	193	141	93	58	37	21	10	1
80	399	315	231	133	83	53	30	13	2
100	727	606	429	237	148	94	54	23	3
125	1190	991	670	370	232	147	85	37	4
150	1600	1334	887	490	306	195	112	48	5
200	2868	2458	1610	935	588	364	208	88	10

VALORES DE Kv / Kv VALUES

Kv (m³/h) = Es la cantidad de metros cúbicos por hora que pasará a través de la válvula generando una pérdida de carga de 1 bar.

Kv (m³/h) = Flow rate of water in cubic meter per hour that will generate a pressure drop of 1 bar across the valve.

CURVA PRESIÓN TEMPERATURA / PRESSURE TEMPERATURE RATING

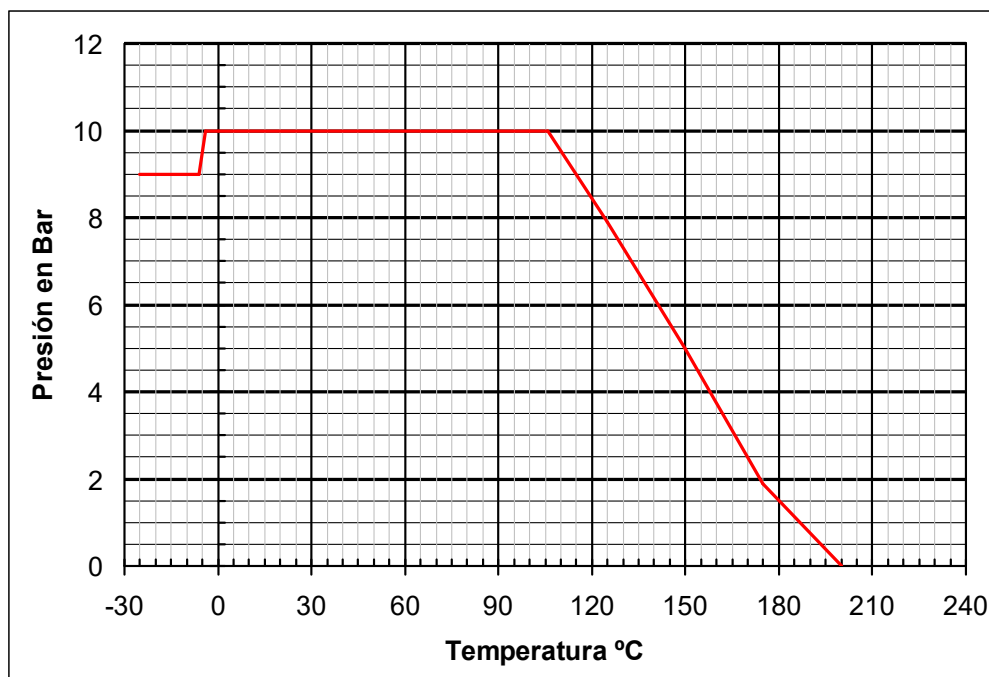

Medidas de Precaución para instalación / Caution measures for Installation:

1. No instale la válvula en posición totalmente cerrada / *Do not assemble the butterfly valve in total closed position.*
2. Verifique el buen paralelismo de las bridas / *Check the good parallelism of the flanges.*
3. No coloque otras juntas entre las bridas / *Do not insert others gasket between flange and valve.*
4. Abra totalmente la válvula antes de apretar las bridas / *Open completely the valve before tightening flanges.*

