

ARTICULO: 2007

Válvula de Esfera paso total Alta Presión. High Pressure full port Ball Valve.

Características

1. Válvula de Esfera Alta Presión.
2. Construcción en Acero al Carbono ASTM A105.
3. Extremos rosca gas (BSP) hembra según ISO 228/1.
4. Material de asientos PEEK.
5. Dispositivo anti-estático.
6. Presión máxima de trabajo 255 bar / 3700 PSI.
(ASME B16.34 Clase 1500)
7. Temperatura de trabajo -30 °C +250 °C.

Features

1. High Pressure Ball Valve.
2. Made of Carbon steel ASTM A105.
3. Gas (BSP) female threads acc. to ISO 228/1.
4. Ball Seat made of PEEK.
5. Anti-static device.
6. Max. Working pressure 255 bar / 3700 PSI.
(ASME B16.34 Class 1500)
7. Working Temperature -30°C +250°C.

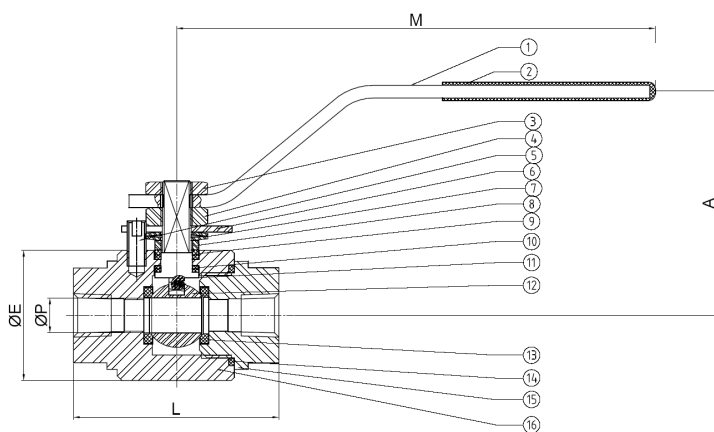

Nº	Denominación / Name	Material	Acabado Superficial/ Surface Treatment
1	Maneta / Handle	Acero Inox AISI 201 / SS 201	-----
2	Funda / Handle Sleeve	Vinilo / Vynil	-----
3	Tuerca Maneta / Handle Nut	Acero Inox AISI 304 / SS 304	-----
4	Tuerca Eje / Stem Nut	Acero Inox AISI 304 / SS 304	-----
5	Prisionero Tope / Stopper Bolt	Acero Inox AISI 304 / SS 304	-----
6	Placa Tope / Stopper Plate	Acero Inox AISI 201 / SS 201	-----
7	Arandela Belleville / Belleville Washer	Acero Inox AISI 301 / SS 301	-----
8	Prensaestopas / Packing nut	Acero Inox AISI 304 / SS 304	-----
9	Estopada / Stem packing	PTFE	-----
10	Arandela / Trust Washer	PTFE	-----
11	Eje / Stem	Acero Inox AISI 304 / SS 304	-----
12	Esfera / Ball	Acero Inox AISI 304 / SS 304	-----
13	Asiento / Ball Seat	PEEK	-----
14	Tórica / O'ring	FKM	-----
15	Tapón / Cap	ASTM A-105	Cincado / Zinc Plated
16	Cuerpo / Body	ASTM A-105	Cincado / Zinc Plated

DIMENSIONES GENERALES / GENERAL DIMENSIONS

Ref.	Medida / Size	PN (PSI)	Dimensiones / Dimensions (mm)					Peso/ Weight (Kg)
			P	A	L	M	E	
2007 02	1/4"	3700	10	70	65	152	41	0,650
2007 03	3/8"	3700	10	70	65	152	41	0,630
2007 04	1/2"	3700	15	74	76	152	49	0,900
2007 05	3/4"	3700	20	87	91	187	59	1,500
2007 06	1"	3700	25	92	100	187	69	2,200

CURVA PRESION TEMPERATURA / PRESSURE TEMPERATURE RATING

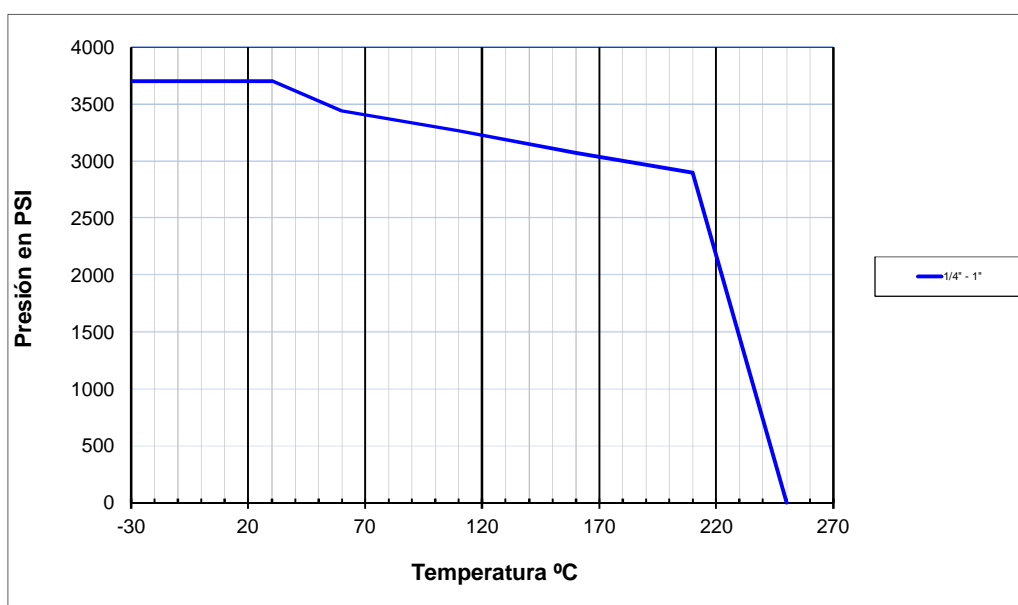

VALORES DE Kv / Kv VALUES

Kv = Es la cantidad de metros cúbicos por hora que pasará a través de la válvula generando una pérdida de carga de 1 bar.

Kv = Flow rate of water in cubic meter per hour that will generate a pressure drop of 1 bar across the valve.

1/4"	3/8"	1/2"	3/4"	1"
6	10	24	43	83